

Model Description

NST

cross flow rectangle
type cooling tower

-

000

water flow

- Space saving, lightweight structures
- good corrosion resistance
- Convenient combination and easy maintenance
- Energy saving, low Noise

Structure

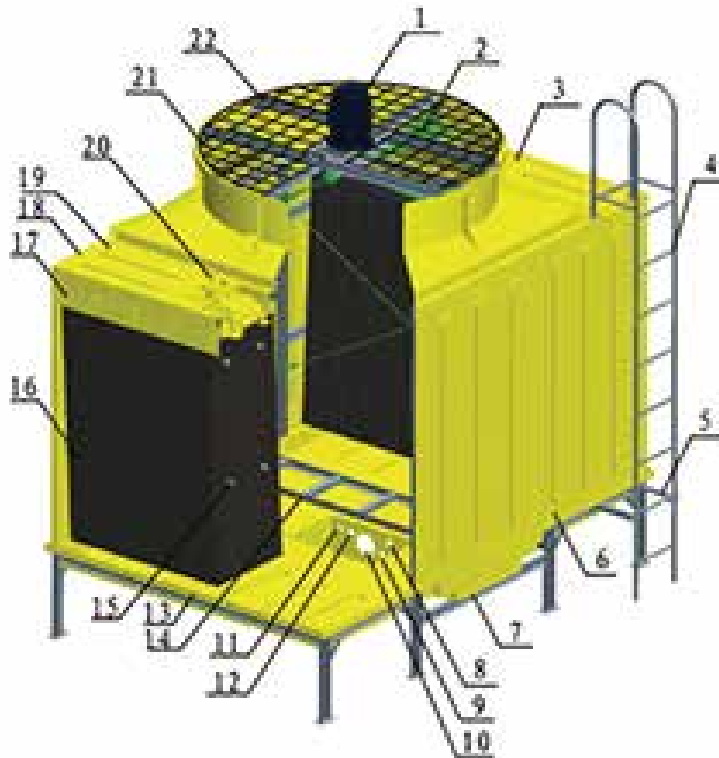

1. Motor
2. Fan
3. Fan stack
4. Ladder
5. Ladder support
6. Casing
7. Tower support
8. Overflow
9. Drain
10. Water outlet
11. Quick feed
12. Auto feed
13. Water basin
14. Access way
15. Infill support
16. Infill
17. Wind shield
18. Distribution basin
19. Distribution basin cover
20. Water distribution
21. Fan guard
22. Motor support

Optional Accessories

- ◆ Noise reduction upgrade
- ◆ Handrail & safety caged ladder
- ◆ Vibration isolator & Rubber mat
- ◆ High- temperature upgrade
- ◆ Anti- Freeze heater
- ◆ Stainless steel framework / bolts and nuts (304/316)

Item Model	Water flow (m ³ /h)	Dimension (mm)			Fan		Water Pressure (Kpa)	Weight (Kg)	
		Length	Width	Height	Diameter (mm)	Motor (Kw)		Dry	Wet
NST-50	50	1450	2700	2720	1200	1.1	32	460	1010
NST-60	60	1450	2700	3260	1200	1.1	34	550	1450
NST-80	80	1600	2820	3700	1500	2.2	36	650	1830
NST-100	100	1980	3200	3700	1500	4	36	860	2260
NST-150	125	2320	3600	3700	1800	4	36	1080	2830
NST-150	150	2600	3800	3700	2100	5.5	38	1180	3550
NST-175	175	2930	3800	3700	2100	5.5	38	1300	3810
NST-200	200	3040	4300	3700	2400	7.5	38	1600	4020
NST-225	225	2950	5080	4100	2400	7.5	40	1710	4150
NST-250	250	3000	5300	4100	2400	7.5	40	2380	5280
NST-300	300	3250	5550	4100	2850	11	40	2580	5650
NST-350	350	3500	5800	4100	2850	11	40	2860	6270
NST-400	400	3750	6050	4250	3200	15	42	3250	6880
NST-450	450	4000	6300	4250	3200	15	42	3660	7350
NST-500	500	4000	6300	4850	3200	18.5	47	4260	8500
NST-600	600	4500	6800	4850	3400	18.5	47	4680	9360
NST-700	700	4500	6800	5500	3700	22	53	5100	10250
NST-800	800	5000	7300	5500	4050	30	53	6100	12300
NST-900	900	5500	7800	5500	4250	30	53	6880	14560
NST-1000	1000	6000	8300	5500	4550	30	53	7660	16800

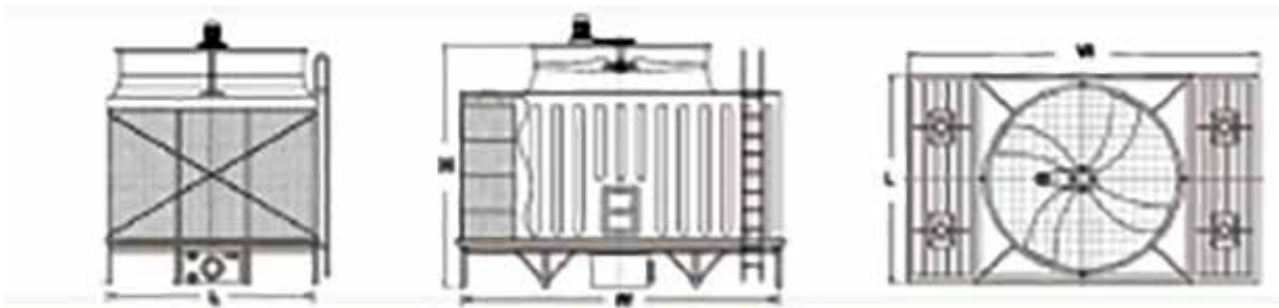

DESIGN CONDITIONS

Entrance temp. $t_1 = 37^\circ\text{C}$ Wet bulb temp. $t_{WB} = 28^\circ\text{C}$
 Leaving temp. $t_2 = 32^\circ\text{C}$ Dry bulb temp. $t_{DB} = 31.5^\circ\text{C}$ Atmospheric pressure $P_0 = 9.94 \times 10^4\text{Pa}$